



# HONG KONG SHUE YAN UNIVERSITY LIBRARY HANDBOOK

2014-2015





The mission of the Hong Kong Shue Yan University Library is to facilitate teaching and promote research in the campus. To fulfil this mission, the Library commits to be:

- ✧ a resource centre by organising various types of materials for learning, teaching and research;
- ✧ a learning centre by offering study areas, discussion rooms and reference services;
- ✧ a user education centre by providing users with library literacy instructions;
- ✧ a service centre by equipping the Library with multi-functional facilities;
- ✧ a library 2.0 centre by interacting with users and designing user-centred services.

# Opening Hours

---

Date	Opening Hours	Circulation Counter	
		Open	Closed
Monday – Friday	<b>8:45 am – 9 pm</b>	9 am	8:45 pm
	5/F: 8:45 am – 8:30 pm	-	-
	6/F: 9:15 am – 8:30 pm	9:15 am	8:30 pm
Saturday	<b>8:45 am – 7 pm</b>	9 am	6:45 pm
	5/F: 8:45 am – 6:30 pm	-	-
	6/F: 9:15 am – 6:30 pm	9:15 am	6:30 pm
Sunday & Public Holidays	Closed		

Announcements of public holidays and special opening hours will be posted on the Library's notice board at the G/F entrance and on the Library homepage.

# General Enquiry

---



## Website

Library Homepage

<http://www.hksyu.edu.hk/lib>

Library Handbook

[http://www.hksyu.edu.hk/lib/download/handbook\\_2014-15.pdf](http://www.hksyu.edu.hk/lib/download/handbook_2014-15.pdf)



## Email

[libinfo@hksyu.edu](mailto:libinfo@hksyu.edu)



## Service Hotlines

Circulation Desk

2104-8284

2104-8285

Information Desks

(2/F) 2806-5113

(3/F) 2806-5114

Learning Commons

2104-8286

Interlibrary Loan Service

2806-5114

[libill@hksyu.edu](mailto:libill@hksyu.edu)



## Address

Shue Yan University Library Complex

12 Wai Tsui Crescent, Braemar Hill Road

North Point, Hong Kong

# Contents

---

<b>Mission</b>	1
<b>Opening Hours</b>	2
<b>General Enquiry</b>	3
<b>Introduction</b>	6
<b>Digital Library</b>	7
A. Catalogue	
B. Homepage	
C. Remote Access	
<b>Collections</b>	9
A. General and Reference Collections	
B. Serials Collection	
C. Newspapers	
D. Special Collection	
Teaching References	
E. Course Reserve Collection	
F. Law Collection	
G. AV Collection	
H. Rare Book Collection	
<b>Electronic Resources</b>	15
A. Electronic Databases	
B. HKSYUtube	
C. Institutional Repository	
D. New e-Books Resources for five academic libraries	
E. E-News	
F. Other Online Resources	
<b>Services</b>	19
A. Lending Service	
B. Alumni Service	
C. User Education Service	

- D. Reference Service
- E. Interlibrary Loan Service
- F. Access to Other Libraries
- G. Other Services
  - For Staff
  - Current Awareness
  - Exhibition Series
  - Staff Publications
  - New Materials

**Facilities** 30

- A. Circulation Desk
- B. Information Desks
- C. Learning Commons
- D. IT Facilities
- E. Noise Level Controlled Areas
- F. Study Facilities
- G. Drinking Fountains

**Liaison Librarians** 36

**Staff Directory** 37

**Regulations** 38

- A. User’s Code of Conduct
- B. Disciplinary Actions
- C. Improper Acts and Penalties

**Classification Schemes** 42

- A. English Materials
- B. Chinese Materials

**Writing Research Papers** 46

- A. Reference Tools
- B. Useful Resources
- C. Plagiarism

**Material Locations** 48

**Floor Plans** 52

## Introduction

---

# 敦 仁

The Hong Kong Shue Yan University (Former: Hong Kong Shue Yan College) was established in 1971. It aims at raising the level of higher education in Hong Kong and strengthening the international academic cooperation with overseas higher education institutions. To support this mission, a new Library complex building was built and opened on 15 November 1995 next to the campus at Wai Tsui Crescent, Braemar Hill Road.

# 博 物

The Hong Kong Shue Yan University Library Complex is a 19-storey multi-functional building. It contains a 6-storey library, seminar rooms, conference rooms, research centres, a podium, a car park, and accommodation for overseas scholars.



# Digital Library

---

## A. Catalogue

### Online Public Access Catalogue (OPAC)

The Library's online catalogue is available wherever the Internet is provided. All the computers located in the Library can be used by readers to search both English and Chinese materials on OPAC. There are printed help sheets explaining how to use OPAC.

## B. Homepage

### Hong Kong Shue Yan University Library Homepage

<http://www.hksyu.edu.hk/lib>

## C. Remote Access

To renew or reserve borrowed items, or access online databases off campus, you need to input your name, barcode and PIN (personal identified number) for authentication. The PIN is a password that you can create and amend by yourself.

SHUE YAN Library

New Search Print Help Login

My Library Help Topics

(More Searches)

Login

Please enter the following information:

Your Name:  E.g., Chan Tai Man OR Chan OR Tai Man

Barcode:  E.g., 28123.....

Your PIN:  The PIN is a password you create yourself.

[Forget Your PIN?](#) [What is PIN? I have forgotten my PIN?](#)



## **PIN Creation**

1. Input [www.hksyu.edu.hk/lib](http://www.hksyu.edu.hk/lib) to access the Library homepage and click “My Circulation Record”.
2. Input your name and barcode as shown on your staff card or student card. Please OMIT the PIN and press the button “Submit”.
3. A new page appears and please input your PIN twice at the fields “Enter your PIN” and “Enter your PIN again”. The PIN is a password created by yourself.
4. You are advised to create the PIN with at least 8 characters or a combination of characters and numbers.
5. Press the button “Submit”.

## **Item Renewal**

1. Go to the Library homepage, and click “My Circulation Record”.
2. Input your name, barcode, and your PIN that has been created, then press “Submit” on the left hand side, you will see “My Circulation Record”. (You can modify your PIN or email address).
3. Select an item you wish to renew, or press the button “Renew all” to get all your items renewed. Then, click “Logout” to leave the page.
4. Overdue items cannot be renewed online.
5. Check the new due date. If the new due date is not shown, please contact the Library staff as soon as possible.

## **Item Request** (for books only)

1. Go to the Library’s online catalogue (<http://lib.hksyu.edu.hk>) to search an item.
2. A due date in the “Status” column means the item is on loan and you can reserve it. Please press the “Request/Recall” button at the upper left hand side.
3. Input your name, barcode and your PIN, and then press “Submit”.
4. Select the item you request, and press the button “REQUEST SELECTED ITEM”.
5. A new page “Your request is successful” is displayed. You will receive a pickup notice through email when the item is returned.
6. You are responsible to validate your correct email address provided in your circulation record.

## Online Database Access

1. Go to the Library homepage and click “Online Databases”.
2. In the Alphabetical or Subject Lists, you can see a brief description of the selected database when you click “Detail”.
3. Input your name, barcode and PIN to authenticate your identity after clicking the name of a database.
4. You need to install electronic readers like CAJ Viewer, Adobe Acrobat Reader or Ebrary reader before accessing databases such as China Academic Journals Full-text Database and Ebrary.
5. The e-journal and e-book titles are also searchable on the Library’s online catalogue.

## Collections

---

The Library collects 300,000 physical items of various types of materials, covering a wide range of subjects and reference sources.



### A. General and Reference Collections

All General Collection items are available for circulation. Chinese items are kept on 2/F, 5/F and 6/F (Closed stacks) while English items are kept on 4/F and 5/F.

All Reference collection items with prefix R are used in the Library only. The collection includes encyclopaedias, dictionaries, directories, yearbooks, almanacs and bibliographies.

## B. Serials Collection



The serials collection is kept on the 3/F, 4/F and 6/F closed stacks. This collection includes over 930 printed titles in both English and Chinese, covering a variety of disciplines.

Current issues of journals are displayed on the front racks. Back issues are bound and the collection



carries the prefix **P** or **RP** on spine labels and catalogue entries. Unbound issues of periodicals are for use in the Library only. Some bound periodicals can be borrowed for 3 days.

## C. Newspapers

This collection includes 29 local and overseas newspapers. Current issues are located on 3/F and 6/F. Some older issues are available on request at the 2/F counter. All newspapers should be read within the Library.

## D. Special Collection

The Special Collection includes annual reports, research papers, student reports, overseas documents and teaching references. Most of the materials are kept in the room of Special Collection on 3/F. A few very old materials are stored on the 6/F close stacks.

Annual reports, research papers, student reports and overseas documents and company reports are available for **3-hour loan with no renewal** and can only be used within the Library. Teaching references are for staff use only.

- ✧ Annual reports
- ✧ Research papers
- ✧ Student reports
- ✧ Overseas documents
- ✧ Teaching references
- ✧ Company reports



### ***Teaching References***

There is a small corner at Special Collection area that houses teaching reference materials and provides a computer and a scanner for teaching staff only.



## **E. Course Reserve Collection**

Textbooks and principal reading materials are kept in the Reserve Collection. These items are available for **3-hour loan with no renewal** and can only be used within the Library. Users can borrow them at the 3/F circulation counter.

## F. Law Collection

The Law Collection is located in the Law Library on 4/F. It consists of English books (Call No. 340 - 349 with Prefix L), Chinese books (Call No. 570 - 589 with Prefix CL), bounded journals (Prefix LP), current issue of journals (Prefix LP) and other reference materials (Prefix RL).



### Law Theses (Peking University)



In particular, our Law Library houses a series of law theses of Peking University (PKU, 北京大學法律論文). The Call Numbers carry Prefix CCB PKU and CC PKU, representing Bachelor's Degree and Master's Degree, respectively. The theses are reference materials and should be used in the Library only.

## G. AV Collection

The AV collection provides users with audio-visual resources including audiocassettes, videotapes, CD-ROMs, VCDs, DVDs and floppy disks. All the materials can be requested at the 6/F Learning Commons.

The following prefixes on spine labels and catalogue entries stand for different types of materials:

- ✧ **AVC** for audio CDs, VCDs, CD-ROMs, and floppy discs
- ✧ **AVD** for DVDs and DVD-ROMs
- ✧ **AVK** for kits
- ✧ **AVR** for reference AV materials
- ✧ **AVS** for audiocassettes
- ✧ **AVV** for videotapes
- ✧ **LTV** for local TV programmes
- ✧ **MC** for language learning kits

Non-print materials accompanied with books which have the prefixes **AVC(C)**, **AVD(C)**, **AVS(C)** and **AVV(C)** are kept at the G/F circulation counter.

## Local TV Programmes

To enrich collection of media materials, the Library has accomplished agreements with Television Broadcasting Ltd (TVB), Asia Television Ltd (ATV) and Radio Television Hong Kong (RTHK) to record some TV programmes for academic and research use.



Students and staff can borrow and watch programmes for 3 hours at the 6/F Learning Commons. The recording, loan or circulation of each TV programme is subject to the official permission from the license.

TVB	ATV	RTHK
星期二檔案 Tuesday Report	Newsline (時事縱橫)	議事論事 LegCo Review
星期日檔案 Sunday Report	文化風情 Cultural Program	鏗鏘集 Hong Kong Connection
財經透視 Financial Magazine	金錢世界 Money Talks	頭條新聞 Headliner
新聞透視 News Magazine	香港風華 Hong Kong Beats	
	時事追擊 News Magazine	
	慧眼商機 Eyes On Mainland Business	
	香港百人 Hong Kong 100 VIPs	



For further details, please refer to:

[http://www.hksyu.edu.hk/lib/site/lc/ltpv\\_themed.html](http://www.hksyu.edu.hk/lib/site/lc/ltpv_themed.html)

## H. Rare Book Collection

In 2007, Shue Yan University was honoured to receive over 10,000 volumes of the Reproductions of Chinese Rare Editions Series (中華再造善本) from the Ministry of Education of China.

The Series is published by National Library of China starting from 2002 and reproduces around 1,300 categories of books. It has five parts: publications from Tang and Song Dynasties, Jin and Yuan Dynasties, Ming Dynasties, Qing Dynasties, and written documents of the Ethnic Minorities. Each of these five parts is further divided into Classics (jing 經), History (shi 史), Philosophy (zi 子), Belles-letters (ji 集) and Collection (cong 叢). This Rare Book Collection is treasured up in the Library.



The Series are all photocopied from the original in terms of size, publishing format and binding. The publications are printed on high quality Xuan paper (宣紙) and munken paper (蒙肯紙). All volumes are thread-bounded with green cover in imitation of that of Grand Secretariat Archives of the Qing Dynasty (清代內閣大庫藏書) and are grouped in a number of protective covering cases (四合式函套). Each category of rare book provides a summary and biographies of authors for the research purpose.

At the presentation ceremony, Professor Yuan Guiren (袁貴仁), the Vice Minister of Education said “... I believe this series will be the best channel for teachers and students to understand Chinese culture. It also helps in the development of teaching and research in the university ...”

The Series is now kept in special cabinets on 2/F and used in the Library only. For information, please consult library staff at the information desk.

# Electronic Resources

---

## A. Electronic Databases



Most of the electronic databases and online services subscribed by the Library are accessible on and off campus.

The electronic items can be searched on the Library catalogue or e-database platforms. Currently, there are over 2 million e-books and nearly 58,000 e-journal titles available. Users can also print the articles from databases.

### List of Online Databases

1. AiritiBooks 華藝中文電子書
2. Asia-Studies Full-text Online
3. Britannica Image Quest
4. CHANT 漢達文庫
5. China Academic Journals Full-text Database 中國期刊全文數據庫(文史哲、政治軍事與法律、教育與社會科學綜合、經濟與管理)
6. China Master Theses Full-text Database 中國優秀碩士學位論文全文數據庫(文史哲專輯)
7. China Proceedings of Conference Full-text Database 中國重要會議論文全文數據庫(文史哲、政治軍事與法律、教育與社會科學綜合、經濟與管理)
8. Chinese Anti-Rightist Campaign Database, 1957- 中國反右運動數據庫, 1957-
9. Chinese Cultural Revolution Database 中國文化大革命文庫
10. Chinese Great Leap Forward and Great Famine Database, 1958-1962 中國大躍進一大饑荒數據庫, 1958-1962
11. Chinese Electronic Periodical Services 中文電子期刊服務
12. Wenyuange Siku Quanshu Electronic Edition - Online Version 《文淵閣四庫全書電子版》網上版
13. Counseling and Psychotherapy Transcripts, Client Narratives, and Reference Works
14. DOAJ (The Directory of Open Access Journals)
15. Ebrary



16. EBSCO: Academic Search Complete
17. EBSCO: ATLA Religion Database with ATLASerials
18. EBSCO: Business Source Complete
19. EBSCO: Communication & Mass Media Complete
20. EBSCO: EconLit with Full Text
21. EBSCO: ERIC
22. EBSCO: European Views of the Americas: 1493-1750
23. EBSCO: Family Studies Abstracts
24. EBSCO: Funk & Wagnalls New World Encyclopedia
25. EBSCO: GreenFile
26. EBSCO: History Reference Centre
27. EBSCO: Library, Information Science & Technology Abstracts with Full Text
28. EBSCO: MAS Ultra - School Edition
29. EBSCO: Military & Government Collection
30. EBSCO: Primary Search
31. EBSCO: PsycARTICLES
32. EBSCO: PsycBOOKS
33. EBSCO: PsycEXTRA
34. EBSCO: Psychology and Behavioral Sciences Collection
35. EBSCO: PsycINFO
36. EBSCO: Regional Business News
37. EBSCO: SocINDEX with Full Text
38. EBSCO: Teacher Reference Center (TRC)
39. EBSCO: Historical Abstracts with Full Text
40. EBSCOhost Electronic Journals Service
41. Economist Historical Archive 1843-
42. Encyclopædia Britannica Online
43. Gale Virtual Reference Library
44. Hong Kong Scholarship Online
45. ICLR Online
46. INFOBANK Online Database Service 中國資訊行 [繁體 / 簡體]
47. IngentaConnect (Staff only)
48. Journal Citation Reports Social Sciences Edition
49. JSTOR: Arts & Science I
50. Learning Portal (Asian)
51. Lexis HK
52. Literature Online
53. McGraw-Hill eBook Library: Business Collection
54. Naxos Spoken Word Library

55. Oxford English Dictionary
56. Oxford Scholarship Online
57. PQDT Open
58. ProQuest Central
59. ProQuest Dissertations & Theses (Abstract & Index): Subset A (Humanities & Social Sciences Collection)
60. ProQuest Entrepreneurship
61. PsycCRITIQUES
62. PsychiatryOnline
63. PsycTESTS
64. Social Science Research Network
65. Social Theory
66. Sociological Abstracts
67. South China Morning Post Digital IP Access Program
68. Taylor & Francis Social Sciences & Humanities Library
69. University Press Scholarship Online: Sociology
70. Video Journal of Counseling and Therapy
71. Wanfang Video 萬方視頻
72. Westlaw China 萬律 [Chinese / English]
73. Westlaw HK
74. WiseNews 慧科電子剪報 & Wisers Information Portal 慧科新聞資料庫
75. World eBook Library (Academic Research, Rare & Special eBook Portal)

For further information of the above databases, please visit:

[http://www.hksyu.edu.hk/lib/site/db\\_campus/bytitle.htm](http://www.hksyu.edu.hk/lib/site/db_campus/bytitle.htm)

## B. HKSUtube

Since 2006, the Library provides recorded local TV programs from three free TV broadcast companies (ATV, RTHK and TVB). Programs are mainly subjected to news and public affairs. For effective preservation and easier access for Library users, some licensed episodes produced are converted into online streaming videos. DVD copies can be found on the 6/F of the Library, or users may login to access restricted resources through HKSUtube for online viewings.

## C. Institutional Repository

Established by the Library, Institutional Repository (IR) primarily collects, stores and distributes the digital scholarly works of faculty, students and staff at Shue Yan University. Now the IR houses more than 2,500 electronic theses and publications. For access, please click the item under “Quick Link” to start at the Library webpage.

## **D. New E-books Resources for Five Academic**

### **Libraries**

The five tertiary institutions including the Open University of Hong Kong, Caritas Institute of Higher Education, Chu Hai College of Higher Education, Tung Wah College and Shue Yan University have been approved a grant of over \$50 million under the Quality Enhancement Support Scheme (QESS) to support in building an online **Collection Sharing and Information Discovery System (CSIDS)** and a new e-book collection. CSIDS provides a next generation search and discovery tool to facilitate faculty members and students among the five libraries to access the Library. As it is currently under construction, the Library lists out the acquired e-book titles in the option “CSIDS Titles” under the pull-down menu “Collections” for access.

### **E. E-News**

The Library subscribes WiseNews, ProQuest and EBSCOHost for news articles in various subjects all over the world. Furthermore, a number of online news webpages are provided for access. For access, please click the item “E-News” under pull-down menu “E-Resources”.

### **F. Other Online Resources**

The Library collects a number of online resources for the purpose of study, language learning and specific information search. For access, please click “Dictionaries & Encyclopedia”, “Language Learning Online” and “Internet Resources” under pull-down menu “E-Resources”

# Services

---

## A. Lending Service

### 1. Registration

All staff and students are automatically entitled to use the services and facilities provided by the Library with their valid staff or student identity cards. Others need to register at the 2/F information counter.

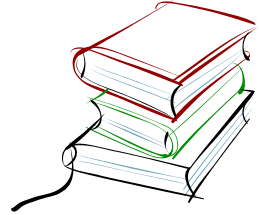

### 2. Borrowing and Returns

The user must show a valid staff card or student identity card when borrowing materials. Most of the Library materials can be borrowed or returned at the G/F circulation counter. AV materials located in the Learning Commons should be borrowed and returned at the 6/F service counter. The card **cannot** be transferred to other users.



CATEGORIES	STAFF				POSTGRADUATES			
	Quota	Loan period	Renewal	Fines	Quota	Loan period	Renewal	Fines
<b>Books</b>	140	90 days*	30 days (3 times)	\$1.5/day	110	90 days	30 days (3 times)	\$1.5/day
<b>AV Materials (accompanied with books)</b>				\$2/day				\$2/day
<b>AV Materials</b>	20	14 days	7 days (once)	\$2/day	20	14 days	7 days (once)	\$2/day
<b>Reserves, Kits (AV) &amp; Local TV Programmes</b>		3 hours	N/A	\$2/hour		3 hours	N/A	\$2/hour
<b>Bound Serials (Prefix P)</b>	10	3 days	N/A	\$2/day	10	3 days	N/A	\$2/day
<b>Reserves (Books &amp; Special Collection)</b>		3 hours		\$2/hour		3 hours		\$2/hour
<b>Teaching References</b>	8	30 days 180 days	N/A	\$1.5/day	N/A			
<b>External Reader Card (IFT (Macau))</b>	1	14 days	N/A	\$5/day	1	7 days	N/A	\$5/day
<b>External Reader Card (BU)</b>		3 days				3 days		
<b>External Reader Cards (Caritas, ChuHai, CityU, CUHK, HKAPA, HKU, HSMC, NYC, TWC, VTC)</b>		14 days						
<b>External Reader Cards (HKIED)</b>								
<b>External Reader Cards (OUHK, Lingnan U)</b>								
<b>Borrower Card (Central Resources Centre, EDB)</b>		3 days						

\* Academic staff can extend 90-day normal loan items to 180 days (with no renewal) for teaching purposes on up to 8 items.

UNDERGRADUATES				ALUMNI (Borrower)				STAFF FAMILY			
Quota	Loan period	Renewal	Fines	Quota	Loan period	Renewal	Fines	Quota	Loan period	Renewal	Fines
80	30 days	30 days (3 times)	\$1.5/day	10	30 days	30 days (3 times)	\$1.5/day	10	30 days	30 days (3 times)	\$1.5/day
			\$2/day				\$2/day				\$2/day
20	7 days	7 days (once)	\$2/day	N/A				N/A			
	3 hours	N/A	\$2/hour	3	3 hours	N/A	\$2/hour	3	3 hours	N/A	\$2/hour
8	3 days	N/A	\$2/day	N/A				N/A			
	3 hours		\$2/hour	5	3 hours	N/A	\$2/hour	5	3 hours	N/A	\$2/hour
N/A				N/A				N/A			
1	7 days	N/A	\$5/day	N/A				N/A			
	3 days										
N/A											

### 3. Book Drops

Library materials can be returned to the book drop located at the Library entrance after the Library closes. An express book drop at the circulation counter is available when the Library opens. The service hours are from Monday to Friday (9 am to 7:30 pm) and Saturday (9 am to 6 pm). **The overdue books, non-print materials, ILL items and bound journals cannot be returned to the book drops.**

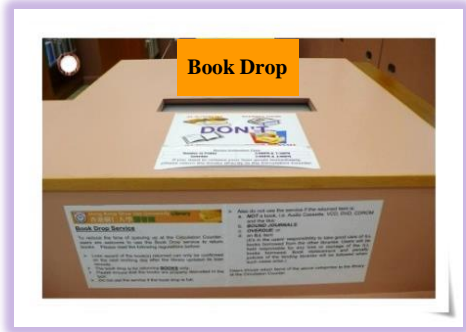

### 4. Circulation Notices

All overdue, courtesy, recall, hold for pick-up and cancellation notices are sent to users' email addresses or mobile phones by SMS. When registering the SMS Alert service, users have to create a Google account with the email address referenced in Library system. Please access <http://www.hksyu.edu.hk/lib/site/subsystem/cal/> for further details.

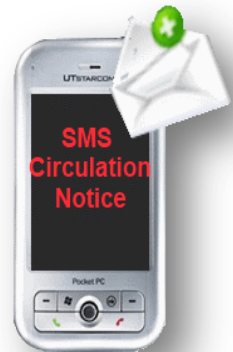

### 5. Fines

Overdue fines may be charged according to different items. If the item is not returned within 30 days from the due date, the borrowing privileges may be suspended. Please refer to pages 20-21 for details.

## 6. Losses or Damage

Users are responsible for taking care of the borrowed materials. Books should never be written on, marked or damaged. For lost or damaged items, the user will be charged the full replacement cost at a current market price, plus \$50 processing fee per item and the accumulated overdue fine if any. Loss of any **out-of-print material** will be charged depending on the evaluated cost.

## 7. Renewals

Borrowed items may be renewed via the Library homepage provided that no other borrower has reserved them and the items are not overdue. If an item is overdue, you may not be able to renew it online. Please refer to pages 7-8 for details.

## 8. Reservations

All checked out books can be reserved at the Library's online catalogue. You will be notified once the book is available. Please refer to pages 7-8 for details.

## 9. Recalls

Books with normal loan period (staff and postgraduates: 90 days; undergraduates: 30 days) are subject to be recalled once they have been reserved by another user. If books are recalled, the original loan period will be shortened. The Library will send a recall notice to inform the current borrower about a change of due date.

Please always check your email notifications. You hold responsible for the return of recalled items. Overdue fines will be charged if items are returned after the new due date.



## B. Alumni Service

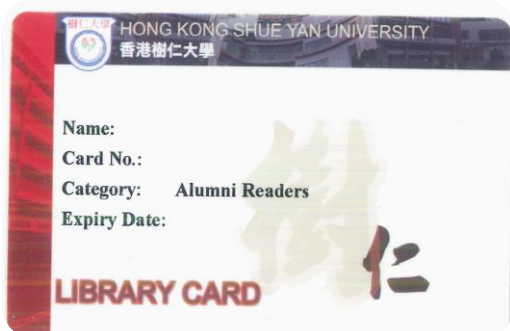

HKSyu awarded local graduates are eligible to apply for Alumni Reader Card or Alumni Borrower Card. Other joint course graduates will be considered on case by case basis.

The admission fee of Alumni Reader Card is \$100 per year.

Card holders can **only** access the HKSyu Library and use the collections (including Course Reserve materials, Special Collection, Local TV Programs and databases) within the Library. The Card does not provide any borrowing privileges throughout the entire valid period.

The admission fee of Alumni Borrower Card is \$1,000 per two years. Card holders can access the HKSyu Library with borrowing privileges throughout the entire valid period. Also, remote access to 13 databases is permitted, which is subject to database providers' terms and conditions.

Applicants should bring the graduation certificate or other equivalent documents, one 1.5x2 inch recent photo and the admission fee to the 2/F information counter to apply for the Alumni Cards. For more information, please visit <http://www.hksyu.edu.hk/lib/site/services.htm>.

## C. User Education Service

### 1. Faculty Requests for Instruction Classes

The Library provides course-related instruction classes upon request. If faculty members wish to set up a customised library instruction session for their students, please email [libinfo@hksyu.edu](mailto:libinfo@hksyu.edu) or call 2806-5114.

## 2. Instruction Programs

Workshops teaching how to use different Library resources are run regularly. Students in group can also request a workshop that fulfils their information needs. Please visit the “Library Instruction Class” page at <http://www.hksyu.edu.hk/lib/workshop/> for further information.



## 3. Orientation

Library orientation sessions are organised for new students at the beginning of each academic year. Additional orientation sessions are available upon request.

## 4. Research Consultation

Research consultation is a scheduled appointment with our Librarians for individual assistance with library research. For further information, please visit <http://www.hksyu.edu.hk/lib/research/>.

## D. Reference Service

If you have any problems or questions in using the Library services or facilities, please feel free to contact our Library staff. Information or instruction leaflets on the usage of Library materials are available at information counters.

## E. Interlibrary Loan Service

Interlibrary loan service is provided to all registered Library patrons who request materials not acquired by the Library. ILL is a **fee-based service**. Users who need to use this service can submit their requests online at <http://www.hksyu.edu.hk/lib/site/ill/index.htm>. For further information, please email [libill@hksyu.edu](mailto:libill@hksyu.edu) or call 2806-5114.

## F. Access to Other Libraries

Library	No. of Cards	Access to E-databases On-site	Reader Groups
Central Resources Centre (Education Bureau)	1	all	Staff only (with borrowing privilege)
Caritas Bianchi College of Careers / Caritas Institute of Higher Education	2	all	Year 1-4 students or above and staff
Chinese University of Hong Kong	3	all	
Chu Hai College of Higher Education	3	all	
City University of Hong Kong	3	most	
Hang Seng Management College	3	all	
Hong Kong Academy for Performing Arts	3	most	
Hong Kong Nang Yan College of Higher Education	3	all	
Institute for Tourism Studies (Macau)	2	none	
Tung Wah College	3	none	
University of Hong Kong	12	most	
Vocational Training Council Libraries	4	most	
Hong Kong Baptist University	1	most	Year 4 students or above and staff
Hong Kong Institute of Education	3	most	Postgraduate students and staff
Lingnan University	3	some	Staff only
Open University of Hong Kong	3	none	

### 1. Borrower Card

The Central Resources Centre of the Education Bureau provides one Borrower Card for our staff with borrowing privilege and access to all e-databases on-site.

### 2. External Reader Cards

Fifteen academic libraries provide External Reader Cards for the HKSU staff and students. Readers can go to the G/F circulation counter to borrow them. External Reader Cards provide access to their own libraries.

Although the printed materials are not allowed to borrow, readers can access some e-databases on-site.

Also, the Hong Kong Central Library issues the Temporary Pass (a duration of 3 days) of the University of Hong Kong Libraries for users. For further information, please visit the Hong Kong Public Libraries website <http://www.hkpl.gov.hk/cindex.html> or call 2921-0222.

Moreover, staff and students can now present current and valid HKSYU staff or student cards to access the Library of Savannah College of Art and Design (SCAD Hong Kong). For details, please visit the website <http://www.scad.edu/hong-kong/index.cfm>.

## G. Other Services

### 1. For Staff

The “For Staff” link (<http://www.hksyu.edu.hk/lib/staff/>) on the Library homepage is to enhance the communication between teaching staff and the Library. It includes the following information:

- ✧ Welcome & Notice
- ✧ Modify Your Information
- ✧ Acquisitions Staff
- ✧ Liaison Librarians & Departmental Coordinators
- ✧ Library Collection Development Policy
- ✧ Interlibrary Loan Service
- ✧ Document Delivery Service – IngentaConnect
- ✧ External Reader Cards
- ✧ Library Policies
- ✧ Library Forms
  - ✓ Recommendation Forms
  - ✓ Online Database Termination Form
  - ✓ Suggestion Form
  - ✓ Interlibrary Loan Form (Online / PDF / MS Word)
  - ✓ Short Loan Request Form (Online / PDF / MS Word)
  - ✓ Thesis / Honor Project / Internship Report Submission Form (PDF / MS Word)
- ✧ Library Documents

## 2. Current Awareness

The Library always provides the latest information on the related subject areas. New books are displayed on the 2/F and 4/F sloping shelves. Lists of new titles can be found on the Library website (see page 29 New Materials). Content pages of the latest issues of serials publications are delivered upon request by Faculty staff. Latest publication catalogues are regularly sent to Departments for reference.

## 3. Exhibition Series

### Permanent Exhibitions

#### ✧ Ten Great National Treasures of Bronze Vessels

The Highlights of the Bronze Vessels are limited to 2,000 sets issued by the National Museum of the Chinese History the first time since its establishment. They are replicas of the ten most representative classical bronze vessels in the Museum Collection.

They reproduce the outstanding achievements of the bronze evolution history from the Shang Dynasty to the Warring States period. A numbered collection certificate from the National Museum of the Chinese History bearing the official copper stamp and signature of the Museum Director is attached to each set.

#### ✧ Twelve Chinese Animal Zodiac and Surname Bronze Wares

The Twelve Chinese Animal Zodiac and Surname Bronze Wares are memorial relics launched by the National Museum of the Chinese History (originally China History Museum) in 2000 to commemorate its 88th Anniversary and welcome the advent of the new millennium. Their characteristics are the mixture of the national relics and Chinese peoples' surnames.

Not only they are high-quality replicas of the First Class National Treasures in limited distribution, they are also contemporary significant bronze

artifacts recording the cultural origins of various surnames. There are 2,000 sets made for each of the 300 Chinese surnames selected globally.

### **Topical Exhibitions**

The Library organises topical exhibitions regularly. For details, please refer to <http://www.hksyu.edu.hk/lib/site/display/index.htm>.

## **4. Staff Publications**



Staff Publications of the Hong Kong Shue Yan University are displayed on 2/F. Some of the publications can be borrowed.

To browse the list, please access:

<http://www.hksyu.edu.hk/lib/display/staffpublications/>

## **5. New Materials**

The Library selects new materials to display every week. New titles are also listed on the Library webpage:

<http://www.hksyu.edu.hk/lib/newtitles.php>

# Facilities

## A. Circulation Desk

The circulation desk is located on G/F where you can borrow and return the Library materials. When you borrow the Library materials, please bring them together with your valid student or staff identity card to the service counter. AV items located in the Learning Commons should be borrowed and returned at the 6/F service counter.



## B. Information Desks

Our Library staff provide assistance in the following aspects:

- ✧ Handling reference enquiries
- ✧ Using the Library catalogue
- ✧ Using equipment such as multifunction printers
- ✧ Accessing electronic resources
- ✧ Referral to Subject Librarians or other institutions and organisations

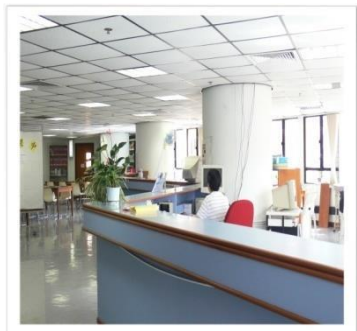

You can submit your enquiry by email:

[libinfo@hksyu.edu](mailto:libinfo@hksyu.edu) or

by phone: 2806-5113, 2806-5114.

The information desks are located on 2/F, 3/F and 6/F.

## C. Learning Commons

The Learning Commons is mainly located on 6/F to enhance self-learning, language learning, research, study and leisure at the University. The space plays a role in the Library as the gathering place for students to study, research and make progress in collaborative settings.



**The major facilities in the Learning Commons include:**



- ✧ Learning Laboratory with 25 PC workstations
- ✧ 2 multi-purpose discussion rooms
- ✧ 4 multimedia stations
- ✧ multifunction printer
- ✧ leisure reading area
- ✧ AV collection
- ✧ TV corner
- ✧ magazine corner
- ✧ multi-purpose presentation room (5/F)
- ✧ activity room (2/F)

### 1. Multimedia Stations

Listening and viewing facilities for Library AV materials are available in the Learning Commons. Please register at the 6/F service counter for remote control.



## 2. Learning Laboratory, Discussion Rooms, Presentation Room, Activity Room

The Learning Commons has a Learning Laboratory and two discussion rooms on 6/F, a presentation room on 5/F, and an activity room on 2/F.



The Learning Laboratory is equipped with 25 PC workstations for private learning, and the booking privilege is limited to staff. The activity room is equipped with tables and chairs for 15 to 26 people in which patron can make a reservation online or by submit an completed application form at least five working days in advance for activity or teaching purposes. The application would be subject to the librarian's approval. Patrons can use the facilities in the Learning Laboratory or activity room on a first come first served basis.

The discussion rooms are capable of 3 to 6 people while presentation room holds 7 to 10 people. These rooms are suitable for group study and meetings. Patrons can place booking in person at the 6/F service counter. Please visit <http://www.hksyu.edu.hk/lib/site/lc/> to view the room booking status before registering.

## D. Teaching References



The Special Collection area on 3/F has a small corner that collects teaching reference materials. Facilities such as computers and scanners are provided for teaching staff only.

# E. IT Facilities

## 1. Wireless LAN

The Library offers wireless Internet access to patrons with wireless-enabled devices. Patrons can access the Internet with their notebooks on G/F, and 2/F to 6/F. Our network supports 802.11b/g/n Wi-Fi devices.



For details, please refer to:

<http://0-www.hksyu.edu.hk.lib.hksyu.edu.hk/pdf/wireless.htm>

## 2. PC Workstations

There are over 81 workstations with printing function on 2/F to 6/F that offer free access to the Internet, online databases and Library catalogue.

Library users can also make use of the Microsoft Office to create Word, Excel and PowerPoint documents. Data analysis and accounting software such as SPSS, DacEasy, and MYOB are installed in workstations. The printing guidelines are available next to each printing machine.

For details, please refer to “Frequently Asked Questions”:

<http://www.hksyu.edu.hk/lib/faq/index.php>



### 3. Photocopying, Printing, Scanning

Multifunction printers are located at 2/F to 6/F. You can pay by Octopus.

	Photocopying		Printing		Scanning
	BW	Colour	BW	Colour	Colour
2-6/F	✓	✓	✓	✓	✓



Copying and scanning of materials in any formats may be illegal without the permission of the copyright owner.

The charges for photocopying and printing are:

Octopus	A4 @2/F-6/F	A3 @2/F-6/F
Black & White	\$0.4	\$0.8
Colour	\$2	\$4
Scanning	Free of charge	

### F. Noise Level Controlled Areas

Three areas in the Library are designed to meet different user needs:

- ✧ **Silent Zone:** 2/F to 4/F (except discussion area on 2/F) for self-studying;
- ✧ **Quiet Zone:** 2/F (discussion area), 5/F and 6/F for group discussion; and
- ✧ **Talking Zone:** quiet talking on mobile phones.

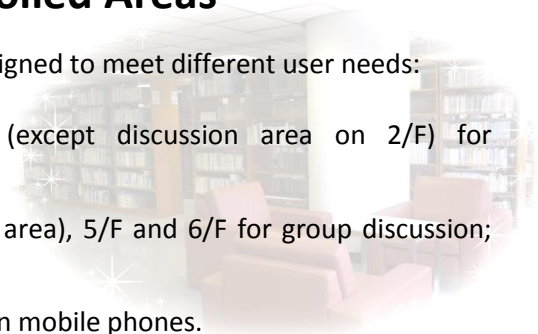

# G. Study Facilities

## 1. Study Desks

The Library provides study carrels on 2/F and 5/F for private study. There are individual desks on 3/F, 4/F and 5/F.

## 2. Discussion Areas

The discussion areas are located on 2/F, 5/F and 6/F. They are separate areas providing large tables for group discussion.

There are also two multi-purpose discussion rooms located in the 6/F Learning Commons, one presentation room on 5/F and one activity room on 2/F. Please refer to page 30 for details of Learning Laboratory / Discussion Rooms / Presentation Room / Activity Room.

# H. Drinking Fountains

Six drinking fountains are installed on each of the Library floors.



# Liaison Librarians

---

In order to enhance the communication between departmental staff and Library, individual Assistant Librarian is responsible for the liaison with the Departments. If Departments have any suggestions and recommendations on Library services, policies or collection development, please contact the Liaison Librarians directly.

Department	Liaison Librarian
Dept. of Accounting	Ms. Danni Feng
Dept. of Business Administration	Ms. Lyn Lam
Dept. of Chinese Language & Literature	Mr. Barry Chow
Dept. of Counselling & Psychology	Ms. Danni Feng
Dept. of Economics & Finance	Ms. Lyn Lam
Dept. of English Language & Literature	Ms. Janet Law
Dept. of History	Mr. Benjamin Chan
Dept. of Journalism & Communication	Ms. Janet Law
Dept. of Law & Business	Mr. Benjamin Chan
Dept. of Social Work	Ms. Rain Chung
Dept. of Sociology	Ms. Sarah Chow

# Staff Directory

---

## University Librarian

Mr. Lee Wai Lun, Desmond

2806 5116

[dessyc@hksyu.edu](mailto:dessyc@hksyu.edu)

## Acquisitions

Mr. Chow Yue Kai, Barry

2806 7318

[libbar@hksyu.edu](mailto:libbar@hksyu.edu)

## Chinese Cataloguing & Collection Development

Mr. Chan Ming Tak, Benjamin

2806 5114

[libmtchan@hksyu.edu](mailto:libmtchan@hksyu.edu)

## Circulation & Information Services

Ms. Chung Yue Ching, Rain

2806 5112

[libchung@hksyu.edu](mailto:libchung@hksyu.edu)

## Collections Management & Library Image

Ms. Law Sheung Yun, Janet

2806 5114

[libsyllaw@hksyu.edu](mailto:libsyllaw@hksyu.edu)

## English Cataloguing & Interlibrary Loan

Ms. Feng Danni

2806 7320

[libfeng@hksyu.edu](mailto:libfeng@hksyu.edu)

## Multimedia & Digital Resources

Ms. Chow Yuet Yu, Sarah

2806 7323

[libchow@hksyu.edu](mailto:libchow@hksyu.edu)

## Projects Development & Quality Assurance

Mr. Kwan Man Tim, Timothy

2806 5115

[libmtkwan@hksyu.edu](mailto:libmtkwan@hksyu.edu)

## Serials

Ms. Lam Yuk Ling, Lyn

2806 7319

[liblyn@hksyu.edu](mailto:liblyn@hksyu.edu)

## Systems

Mr. Paul Chui

2806 7321

[libpaul@hksyu.edu](mailto:libpaul@hksyu.edu)



# Regulations

---

## A. Users' Code of Conduct

1. Admission to the use of the University Library is conditional upon the observance of these regulations made by or with the authority of the Library Committee. Anyone who is believed to violate the Library regulations, disturb readers or mutilate the Library materials may be excluded from the Library and all privileges of using the Library services may be suspended. All Library users are presumed to know its regulations and rules before using the Library services and facilities.
2. All members of the Library staff are empowered to enforce Library regulations.
3. All library users must present a valid library membership card at the entrance of the Library building complex.
4. The Librarian has discretion to restrict certain categories of material held by the Library from being borrowed.
5. Library users are not permitted to bring food or drink.
6. Smoking, including electronic cigarettes, is not permitted in the Library.
7. No games of any form are allowed in the Library.
8. No wet umbrellas or raincoats should be brought into the Library.
9. Reproduction or duplication of audio-visual materials or computer software without permission from the copyright owner is strictly prohibited.
10. Photocopying of Library materials should be made in compliance with the Copyright Ordinance. Library users are fully responsible for any legal consequences arising from infringement of applicable copyright laws.
11. Persons causing a nuisance (by talking or otherwise) or obstructing the proper use of the Library premises may be excluded by any Library staff.

12. Readers must not change the disposition of any Library furniture or equipment without the permission of the Library staff.
13. Please report lost books or damaged Library facilities to Library staff.
14. Please keep your valuables with you at all times. The Library assumes no responsibility for personal belongings left in the Library.
15. Do not exit with any Library items which have not been properly checked out at the Circulation Counter or other Information Counters. If a reader is found leaving the Library with materials that have not been properly checked out and intentional violation is proved, a report will be submitted to the Student Disciplinary Committee for necessary disciplinary action.
16. Please return all loaned materials upon graduation, withdrawal or cessation of employment from the University.
17. Please treat Library staff and fellow users with respect and courtesy.
18. Do not reserve or hide the Library materials intentionally so that other readers cannot use or find the materials.
19. Please take good care of all the Library materials, as users are responsible for their checked out items.
20. Do not use your belongings, textbooks or notebooks to occupy a reading seat. Items left unattended on desk more than half an hour will be cleared away.
21. Lockers are provided at the 2/F entrance.
22. Readers are not permitted to use any apparatus production to make noise. Mobile phones, pagers or the other apparatus must be set to silent mode in the Library. A public telephone is located near the Library entrance on G/F. Photograph or video shooting in the Library should be applied beforehand.
23. Notices must not be displayed or distributed by readers in any part of the Library.
24. Please do not sleep in the Library.
25. Users may be referred to the University Authority if they are found guilty of infringement of the Library regulations.



## B. Disciplinary Actions

Breach of the Library regulations may lead to the following disciplinary actions:

No. of offences within an academic year	Disciplinary action
First offence	Name recorded by Library
Second offence	All Library privileges* suspended for <b>2 weeks</b> with immediate effect
Third offence	All Library privileges* suspended for <b>1 month</b> with immediate effect
Fourth offence or above	All Library privileges* suspended for <b>2 months</b> with immediate effect for each offence thereafter

**\* including access and borrowing privileges**

If a Library user is found offending the Library regulations repeatedly, in addition to the disciplinary action listed for the cases, the Librarian shall have discretion to suspend the Library privileges of the user for **more than two months**. For HKSYU students, the cases may also be referred to the Student Disciplinary Committee for further action.

# C. Improper Acts and Penalties

## Incident 1

Improper acts	Disciplinary actions
<p>(a) A HKSJU Library user found leaving the Library with Library material(s) not checked out, either in hand or in a bag, for the first time within an academic year; or</p> <p>(b) Lending / borrowing the Library Card to / from another person for accessing the Library and / or borrowing Library material(s) for the first time within an academic year.</p>	<ul style="list-style-type: none"> <li>✧ Name will be recorded by the Library.</li> <li>✧ Verbal warning to be given to the offender(s) by Library staff.</li> </ul>

## Incident 2

Improper acts	Disciplinary actions
<p>(a) A HKSJU Library user found committing Incident 1 improper acts twice or more within an academic year; or</p> <p>(b) A HKSJU Library user found mutilating Library material(s) at any time.</p>	<ul style="list-style-type: none"> <li>✧ Name will be recorded by Library staff.</li> <li>✧ Suspension of all Library privileges for one month.</li> <li>✧ Library user is required to pay for the damaged materials.</li> <li>✧ A warning letter will be issued to the offender(s), and for HKSJU students, the warning letter will be copied to: 1. Registry; 2. Dean of OSA</li> </ul>

## Incident 3

Improper acts	Disciplinary actions
<p>A HKSJU Library user found committing Incident 2 improper acts twice or more within an academic year.</p>	<ul style="list-style-type: none"> <li>✧ Librarian shall have discretion to suspend all Library privileges of the user for a period of <b>3 months</b> or longer, depending on the seriousness of the offences.</li> <li>✧ For students, the case may also be referred to the Student Disciplinary Committee for further action.</li> <li>✧ Library user is required to pay for the damaged materials.</li> </ul>

# Classification Schemes

---

Users should understand the classification scheme in order to search a particular item in the Library. Please check the item on our Online Catalogue first before locating the Library materials.

## A. English Materials

English materials are classified and shelved according to Dewey Decimal Classification. A general DDC Scheme is listed below:

- 000 Computer science, information & general works**
  - 000 Computer science, knowledge & systems
  - 010 Bibliographies
  - 020 Library & information sciences
  - 030 Encyclopedias & books of facts
  - 040 [Unassigned]
  - 050 Magazines, journals & serials
  - 060 Associations, organisations & museums
  - 070 News media, journalism & publishing
  - 080 Quotations
  - 090 Manuscripts & rare books
- 100 Philosophy & psychology**
  - 100 Philosophy
  - 110 Metaphysics
  - 120 Epistemology
  - 130 Parapsychology & occultism
  - 140 Philosophical schools of thought
  - 150 Psychology
  - 160 Philosophical logic
  - 170 Ethics
  - 180 Ancient, medieval & eastern philosophy
  - 190 Modern western philosophy
- 200 Religion**
  - 200 Religion
  - 210 Philosophy & theory of religion
  - 220 The Bible
  - 230 Christianity
  - 240 Christian practice & observance
  - 250 Christian pastoral practice & religious orders
  - 260 Christian organisation, social work & worship
  - 270 History of Christianity
  - 280 Christian denominations
  - 290 Other religions
- 300 Social sciences**
  - 300 Social sciences, sociology & anthropology
  - 310 Statistics
  - 320 Political science
  - 330 Economics
  - 340 Law
  - 350 Public administration & military science
  - 360 Social problems & social services
  - 370 Education
  - 380 Commerce, communications & transportation
  - 390 Customs, etiquette & folklore
- 400 Language**
  - 400 Language

410	Linguistics
420	English & Old English languages
430	German & related languages
440	French & related languages
450	Italian, Romanian & related languages
460	Spanish, Portuguese, Galician
470	Latin & Italic languages
480	Classical & modern Greek languages
490	Other languages
<b>500</b>	<b>Science</b>
500	Science
510	Mathematics
520	Astronomy
530	Physics
540	Chemistry
550	Earth sciences & geology
560	Fossils & prehistoric life
570	Biology
580	Plants (Botany)
590	Animals (Zoology)
<b>600</b>	<b>Technology</b>
600	Technology
610	Medicine & health
620	Engineering
630	Agriculture
640	Home & family management
650	Management & public relations
660	Chemical engineering
670	Manufacturing
680	Manufacture for specific uses
690	Construction of buildings
<b>700</b>	<b>Arts &amp; recreation</b>
700	Arts
710	Area planning & landscape architecture
720	Architecture
730	Sculpture, ceramics & metalwork
740	Graphic arts & decorative arts
750	Painting
760	Printmaking & prints
770	Photography, computer art, film, video
780	Music
790	Sports, games & entertainment
<b>800</b>	<b>Literature</b>
800	Literature, rhetoric & criticism
810	American literature in English
820	English & Old English literatures
830	German & related literatures
840	French & related literatures
850	Italian, Romanian & related literatures
860	Spanish, Portuguese, Galician literatures
870	Latin & Italic literatures
880	Classical & modern Greek literatures
890	Other literatures
<b>900</b>	<b>History &amp; geography</b>
900	History
910	Geography & travel
920	Biography & genealogy
930	History of ancient world (to ca. 499)
940	History of Europe
950	History of Asia
960	History of Africa
970	History of North America
980	History of South America
990	History of other areas

## B. Chinese Materials

Chinese materials are classified and shelved according to the New Classification Scheme for Chinese Libraries (中文圖書分類法). The Outline of the Classification Tables is listed below:

### 000 總類

- 000 特藏
- 010 目錄學；文獻學
- 020 圖書資訊學；檔案學
- 030 國學
- 040 普通類書；普通百科全書
- 050 連續性出版品；期刊
- 060 普通會社；博物館學
- 070 普通論叢
- 080 普通叢書
- 090 群經

### 100 哲學

- 100 哲學總論
- 110 思想；學術
- 120 中國哲學
- 130 東方哲學
- 140 西洋哲學
- 150 邏輯學
- 160 形上學
- 170 心理學
- 180 美學
- 190 倫理學

### 200 宗教

- 200 宗教總論
- 210 宗教學
- 220 佛教
- 230 道教
- 240 基督教
- 250 伊斯蘭教
- 260 猶太教
- 270 其他宗教
- 280 神話
- 290 術數；迷信

### 300 科學

- 300 科學總論
- 310 數學
- 320 天文學
- 330 物理學
- 340 化學
- 350 地球科學；地質學
- 360 生物科學
- 370 植物學
- 380 動物學
- 390 人類學

### 400 應用科學

- 400 應用科學總論
- 410 醫藥
- 420 家政
- 430 農業
- 440 工程
- 450 礦冶
- 460 化學工業
- 470 製造
- 480 商業：各種營業
- 490 商學：經營學

### 500 社會科學

- 500 社會科學總論
- 510 統計
- 520 教育
- 530 禮俗
- 540 社會學
- 550 經濟
- 560 財政
- 570 政治
- 580 法律
- 590 軍事

**600 史地**

- 600 史地總論
- 610 中國史地
- 620 中國斷代史
- 630 中國文化史
- 640 中國外交史
- 650 中國史料
- 660 中國地理
- 670 中國地方志
- 680 中國地理類志
- 690 中國遊記

**700 世界史地**

- 710 世界史地
- 720 海洋志
- 730 亞洲史地
- 740 歐洲史地
- 750 美洲史地
- 760 非洲史地
- 770 大洋洲史地
- 780 傳記
- 790 文物考古

**800 語言文學**

- 800 語言學總論
- 810 文學總論
- 820 中國文學
- 830 中國文學總集
- 840 中國文學別集
- 850 中國各種文學
- 860 東方文學
- 870 西洋文學
- 880 其他各國文學
- 890 新聞學

**900 藝術**

- 900 藝術總論
- 910 音樂
- 920 建築美術
- 930 雕塑
- 940 繪畫；書法
- 950 攝影；電腦藝術
- 960 應用美術
- 970 技藝
- 980 戲劇
- 990 遊藝及休閒活動

# Writing Research Papers

---

## A. Reference Tools

The skill of using reference tools is very important in university study. Users are highly recommended to acquire certain knowledge and skills of reference tools. Some basic reference tools with special functions include:



- ✧ Almanacs
- ✧ Atlas
- ✧ Dictionaries
- ✧ Directories
- ✧ Encyclopedia
- ✧ Yearbooks

## B. Useful Resources

1. **Academic writing: a handbook for international students** (3rd ed.) / Stephen Bailey. (2011)
2. **Form & style: research papers, reports, theses** / Carole Slade, Robert Perrin. (2008)
3. **How to write an assignment: proven techniques from a chief examiner that really get results** / Pauline Smith. (2009)
4. **Succeeding with your master's dissertation: a step-by-step handbook** / John Biggam. (2008; e-book 2011)
5. **Writing analytically** (7th ed.) / David Rosenwasser, Jill Stephen. (2015)
6. **Writing essays for dummies** / Mary Page, Carrie Winstanley. (2009)
7. **Writing research papers: a complete guide** (14th ed.) / James D. Lester, James D. Lester, Jr. (2012)

8. **Writing with style: APA style made easy** (5th ed.) / Lenore T. Szuchman. (2011)

## C. Plagiarism

Plagiarism is an act of stealing others' originality. It is a serious crime in the academic field, and may lead to disqualification or penalty on your research work or degree attainment.

Students are recommended to join the Library workshop of "Plagiarism and citing resources for research". The University has subscribed to "VeriGuide" system for checking cited sources.





# Material Locations

Materials	OPAC	Location	Checkout	Example
Books (English)		4/F & 5/F English Book	Yes	940.5421421 FOR 2004 D-Day 1944: Sword Beach and the British airborne landings
Books (Chinese)		2/F, 5/F & 6/F Chinese Book	Yes	731.272 711 明治維新:日本邁向現 代化的歷程
Oversized books (English)	O	4/F & 5/F Oversized Book	Yes	O 299.56113 PIG Japanese mythology
Oversized books (Chinese)	O	2/F & 6/F Oversized Book	Yes (Books at 6/F LIB USE ONLY)	O 300.81 709 1985 大自然一千個為什麼
Serials (current & bound issues)	P / RP	3/F & 6/F Periodical	LIB USE ONLY or 3 DAY LOAN	P 361.3 BJSW British journal of social work
Law books (English)	L 340-349	4/F & 5/F Law Library (English Book)	Yes	L 346.4202 BEA 2008 Contract: cases and materials
Law books (Chinese)	CL 570-589	4/F Law Library (Chinese Book)	Yes	CL 580 1508 法學總論
Law serials (current & bound journals)	LP	4/F & 6/F Law Library	LIB USE ONLY	LP 340.05 LQR Law quarterly review
Law references	RL	4/F & 5/F Law Library	LIB USE ONLY	RL 346.2048 PEN 2006 Intellectual property rights: HKSAR and People's Republic of China
Law theses	CC / CCB	4/F Law Library	LIB USE ONLY	CCB PKU 346.048 LI 論互聯網對知識產權 的侵犯

Materials	OPAC	Location	Checkout	Example
References: general (English)	R	4/F & 5/F English Reference	LIB USE ONLY	R 920.02 WHO 2013 Who's who in the world, 2013
References: dictionaries (English)	RD	4/F & 5/F English Dictionary Reference	LIB USE ONLY	RD 658.8003 DOY 2011 A dictionary of marketing
References: encyclopedia (English)	RE	4/F & 5/F English Encyclopedic Reference	LIB USE ONLY	RE 361.303 ENC 2011 Encyclopedia of social work
References (Chinese)	R	2/F Chinese Reference; Wanchai Campus	LIB USE ONLY or NOT CIRCULATED	R 802.3 1004 2008 朗文中文新詞典
7 days loan (English)		4/F English Book	7 DAY LOAN	616.89 CAS 2012 Case studies in abnormal psychology
7 days loan (Chinese)		2/F Chinese Book	7 DAY LOAN	197 716 2012 c.2 放下傷痛:助人及自助 手冊
3 days loan (English)		G/F & 4/F English Book	3 DAY LOAN	337 APP 1998 International economics: trade theory and policy
3 days loan (Chinese)		G/F & 2/F Chinese Book	3 DAY LOAN	32 1506 2011 國學導讀
Reserve collection (3 hours loan)		3/F Course Reserve Collection & 6/F LC Course Reserve AV	LIB USE ONLY & 3 HOUR LOAN	791.43095125 TEO Hong Kong cinema: the extra dimensions  SOC CHAN C 30 ASK 3/F STAFF 中國的孝敬與印度的 檀施  AVC 791.43 YAN ASK 6/F STAFF 胭脂扣

Materials	OPAC	Location	Checkout	Example
Special collection (annual reports, company reports, research papers, theses)		3/F & 6/F Special Collection	LIB USE ONLY & 3 HOUR LOAN	COMP/BOC Bank of China Ltd. annual report = 中國 銀行年度報告.  .CHK 306.736 HUN 婚外情問題熱線統計 報告  .CUHK 380.1 KEO ASK 2/F STAFF Launching a new American chocolate candy in Hong Kong: case series
Teaching references	TR	3/F SC Teaching Reference	FOR TEACHERS ONLY	TR 802.58025 816 2005 漢語普通話語音教學 示意圖
ACCA items		5/F Accounting	Yes	658.15076 ACCA/AFL ACCA lynchpin. Part 3, paper 3.7, Strategic financial management
CD-ROMs, audio CDs, video CDs & floppy disks	AVC	6/F LC CD/CD-ROM, AVC	Yes	AVC 307.105 HKRC Regional Council annual report
DVDs, DVD-ROMs	AVD	6/F LC DVD, AVD	Yes	AVD 791.43 PRID Pride and prejudice
Reference AV materials	AVR	6/F LC Reference AV, AVR	LIB USE ONLY & 3 HOUR LOAN	AVR 423 WOR Wordpower dictionary
Audiocassettes	AVS	6/F LC Sound Recording, AVS	Yes	AVS 121.8 SI 思入風雲
Videocassettes	AVV	6/F LC Videocassette, AVV	Yes	AVV 658.406 DEA Dealing with crisis and transition

Materials	OPAC	Location	Checkout	Example
CD-ROMs, floppy disks	AVC(C)	G/F Counter CD/CD-ROM (VCD, AUDIO CD)	Yes	02877 ASK G/F STAFF 遊園驚夢二十年
Audiocassettes	AVS(C)	G/F Counter Sound Recording, AVS(C)	Yes	AVS(C) 428.0076 KIN 01296 ASK G/F STAFF Building skills for the TOEFL test
Videocassettes	AVV(C)	G/F Counter Videocassette, AVV(C)	Yes	AVV(C) 158.3 COR 02850 ASK G/F STAFF Student workbook and video for The art of integrative counseling
Language learning kits	MC	6/F LC Language Learning, MC	LIB USE ONLY & 3 HOUR LOAN	MC 495.183 SHANG 商貿普通話
Kit sets	AVK	6/F LC Kits, AVK	LIB USE ONLY & 3 HOUR LOAN	AVK 362.29 DANG 當生命遇上生命教材 套
Local TV programmes	LTV	6/F LC Local TV Prog., LTV	LIB USE ONLY & 3 HOUR LOAN	LTV 306.095125 WEN 2006/03/05-19 瑞士及佛山剪紙聯展
Sewn books	S	2/F & 5/F Sewn Book Reference (Counter Request)	LIB USE ONLY	S282 708 山海經地理今釋

# Floor Plans

G/F

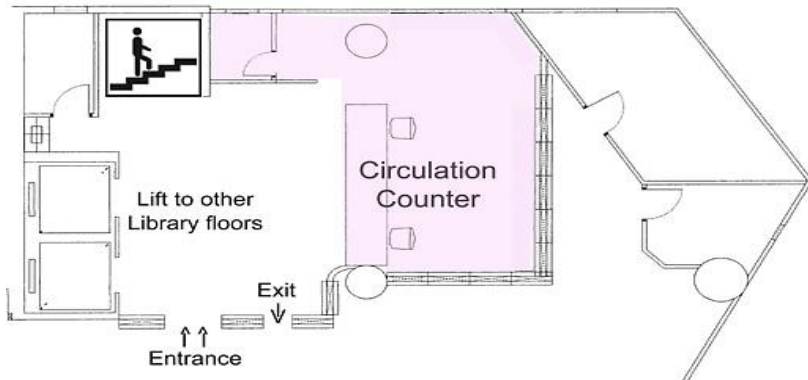

2/F

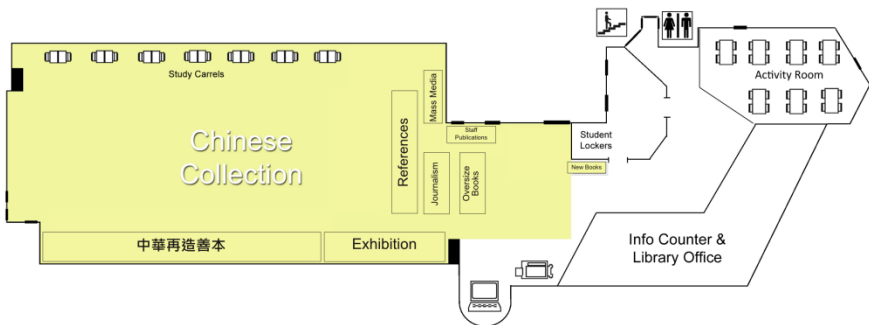

### 3/F

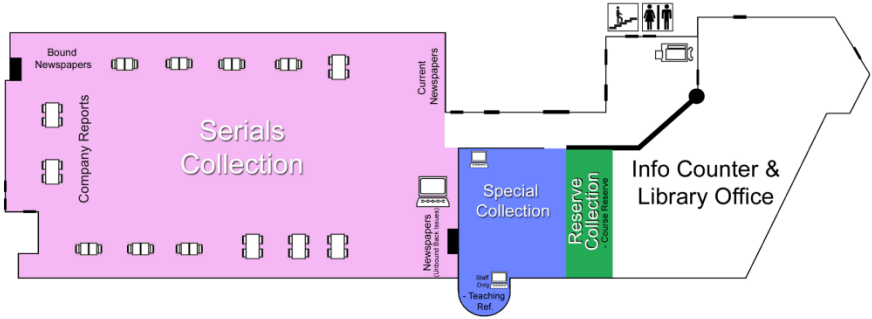

### 4/F

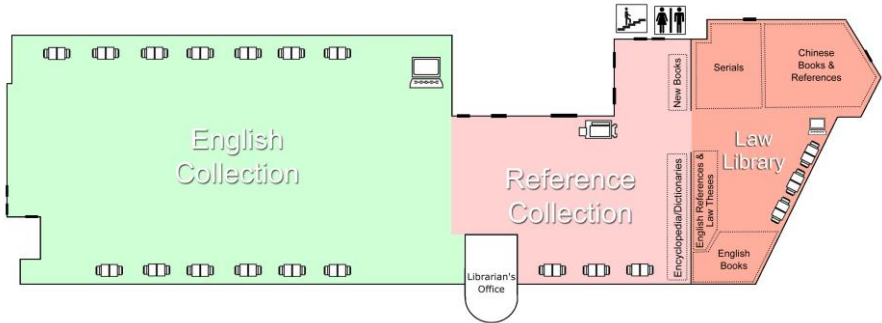

## 5/F

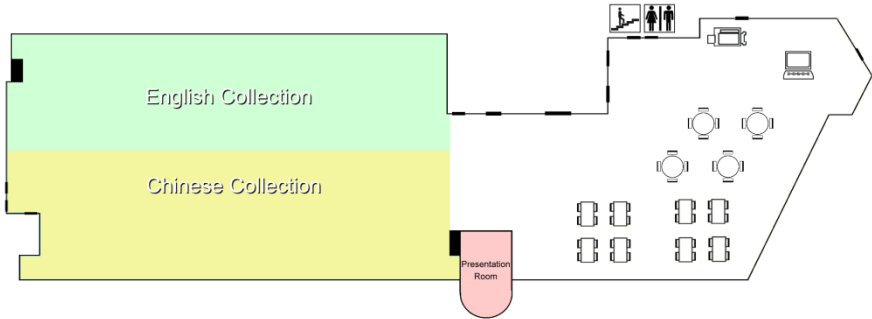

## 6/F

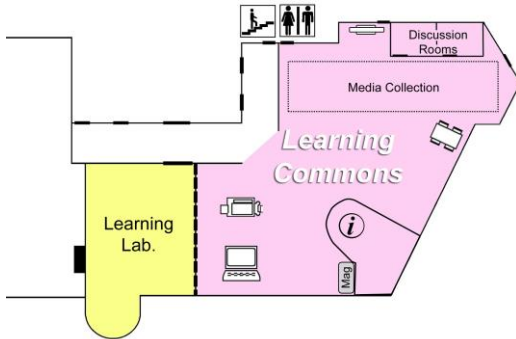

### LEGEND

-  Information Counter
-  Computer Workstations
-  Multifunction Printer
-  HDTV
-  Magazine Corner
-  Individual Desk
-  Round Table
-  4-6 Seater Table
-  Stairs from G/F to 6/F
-  Toilet

Copyright © Hong Kong Shue Yan University Library  
August 2014





Shue Yan University Library Complex  
12 Wai Tsui Crescent, Braemar Hill Road  
North Point, Hong Kong

Tel: 852 2806 5113

Fax: 852 2806 8044

Email: [libinfo@hksyu.edu](mailto:libinfo@hksyu.edu)